

Name	t.mizowaki	Temp	°C	Engine	OS T1201	Muffler	OS
Date	2014.12.14	Humidity	%	Head Clearance	mm	Fuel Type	cosmo
Track	BOSS	Traction	%	Plug No.		Radio	Futaba

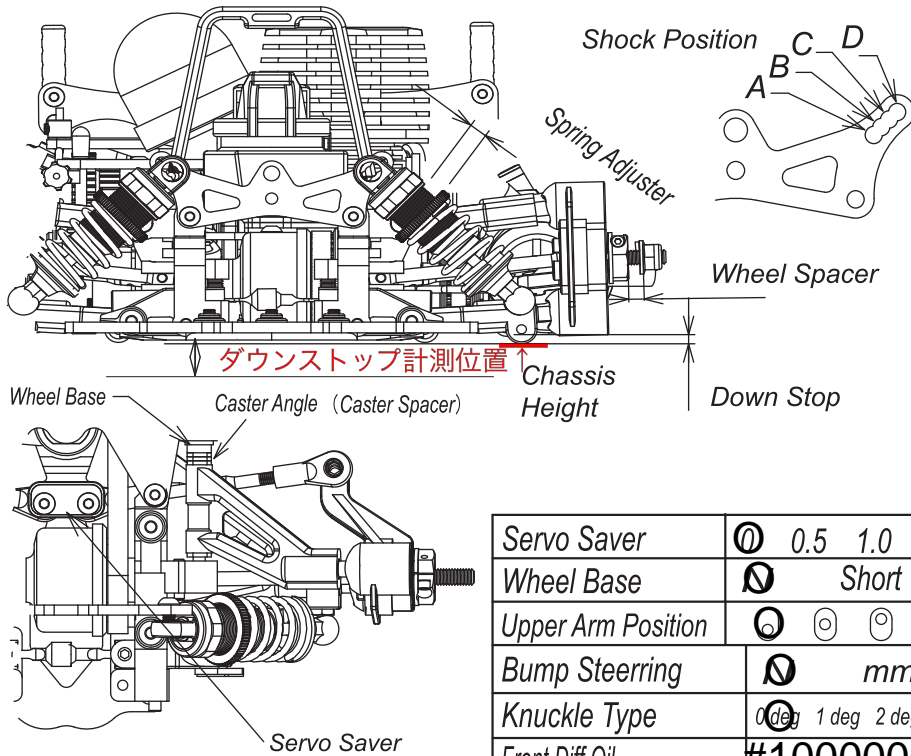

Shock Oil	300 350 400 450 <input checked="" type="radio"/> 550 600 700 800
Diaphragm	<input checked="" type="radio"/>
Shock Piston	<input checked="" type="radio"/>
Spring	kyosho light blue
Spring Adjuster	about mm
Shock Position	A <input checked="" type="radio"/> B C D
Caster Angle (Spacer)	2 mm
Camber Angle <input checked="" type="radio"/> 1G	L 0 0.5 <input checked="" type="radio"/> 1 1.5 2 2.5 3 R 0 0.5 <input checked="" type="radio"/> 1 1.5 2 2.5 3
Toe Angle	-1 deg
Front Width	198 mm
Down Stop	-2 mm
Wheel Spacer	0 mm
Antiroll Bar	VZ084SS Super Soft <input checked="" type="radio"/> / Sway (φ) mm VZ084S Soft
Tire	BOSSリサイクル / S.S.R deg
Wheel Offset Type	mm
Tire Diameter	□ 63.5 mm
Chassis Height	7 mm
Used Optional parts	

Servo Saver	<input checked="" type="radio"/> 0.5 1.0
Wheel Base	<input checked="" type="radio"/> Short
Upper Arm Position	<input checked="" type="radio"/> <input type="radio"/> <input type="radio"/>
Bump Steering	<input checked="" type="radio"/> mm
Knuckle Type	<input checked="" type="radio"/> 0 deg 1 deg 2 deg
Front Diff Oil	#1000000

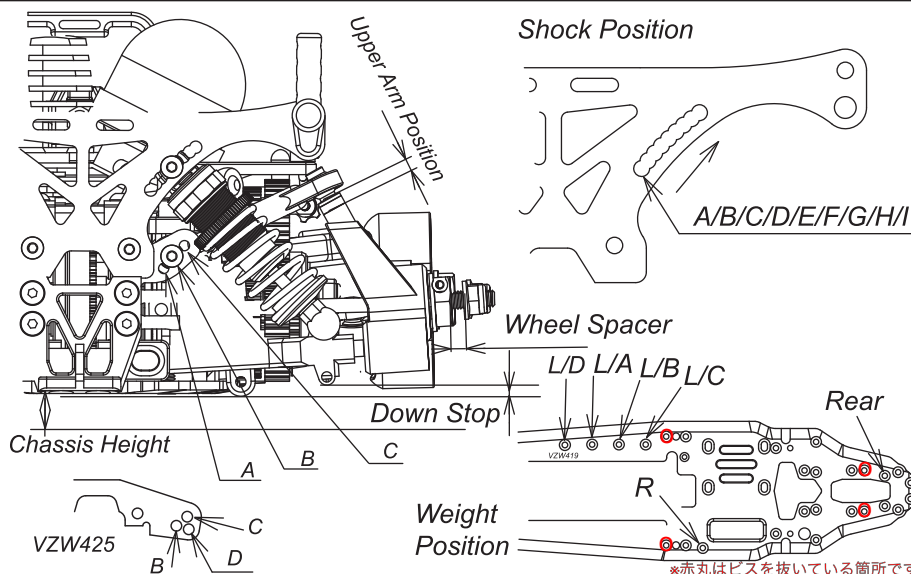

Shock Oil	300 350 400 450 <input checked="" type="radio"/> 550 600 700 800
Diaphragm	<input checked="" type="radio"/>
Shock Piston	<input checked="" type="radio"/>
Spring	kyosho light blue
Spring Adjuster	about mm
Shock Position	<input checked="" type="radio"/> A/B/C/D/E/F/G/H/I
Wheel Spacer	0 mm
Upper Arm Position	1 mm A/B/C/D <small>VZW425</small>
Camber Angle <input checked="" type="radio"/> 1G	L 0 0.5 1 1.5 2 2.5 <input checked="" type="radio"/> 3 3.5 4 R 0 0.5 1 1.5 2 2.5 <input checked="" type="radio"/> 3 3.5 4
Toe Angle	3 deg
Rear Width	199 mm
Down Stop	-2 mm
Antiroll Bar	N2.1mm
Tire	BOSSリサイクル / R38 deg
Wheel Offset Type	mm
Tire Diameter	□ 65.5 mm
Chassis Height	8 mm

Gear	Total	Gear	Total	Gear	Total	Gear	Total	Gear	Total	Gear	Total
16	61	7.63	16	60	7.50	16	59	7.38	21	56	5.33
17	61	7.18	17	60	7.06	17	59	6.94	22	56	5.09
							59		23	56	4.87
									23	55	4.78
									23	54	4.69

Clutch Type	<input checked="" type="radio"/> VZW229	Pinion Gear	(15) 16 <input checked="" type="radio"/> 17 (20) 21 <input checked="" type="radio"/> 22 23
Clutch Shoe	N / VZW229-03 Yellow	Spur Gear	59 60 <input checked="" type="radio"/> 61 / 54 <input checked="" type="radio"/> 55 56
Clutch Weight	<input checked="" type="radio"/> Other ()	Drive Ratio	0mm Difference (24T Pully 387Belt)
Clutch Spring	N (□1.7) / VZW44 <input checked="" type="radio"/> (□1.8)		2.5mm Difference (23T Pully 384Belt)
Clearance	0.7 mm	Rear Diff Oil	#50000
Adjust Nut	1.7 mm	Main Chassis	N (VZ437) / VZW419
		Lower Arm Position	<input checked="" type="radio"/> (ZERO) <input type="radio"/> (OUT 1mm)
		Weight	L(A/B/C/D) / R / Rear <small>VZW419</small>
		Wheel Base	<input checked="" type="radio"/> Short
		Body-Shell	Protoform P-37N

Memo オプションパーツ:SPブレーキパッド(MP777/WC) IFW330、アルミサ-ボセイバー (R4) VZW404、カーボンフロントバンパープレートセット (R4) VZW411、ユニバーサルスイングシャフトセット (R4/リヤ用/2pcs) VZW413、アルミブレーキレバー (R4) VZW421、アルミフロントアッパーパルクセット (L/R/R4) VZW423、アルミリヤパルクアッパーセット (L R/R4) VZW425 ※Fのみドッグボーン使用