

NAME	Takaaki Shimo	TEMP	°C	ENGINE	Sirio	MUFFLER	Sirio 2013
DATE	2003 9/15-20	HUMIDITY	%	HEAD CLEARANCE	mm	FUEL TYPE	TRINITY
TRACK	USA	TRACTION	%	PLUG No.		RADIO	SANWA M8

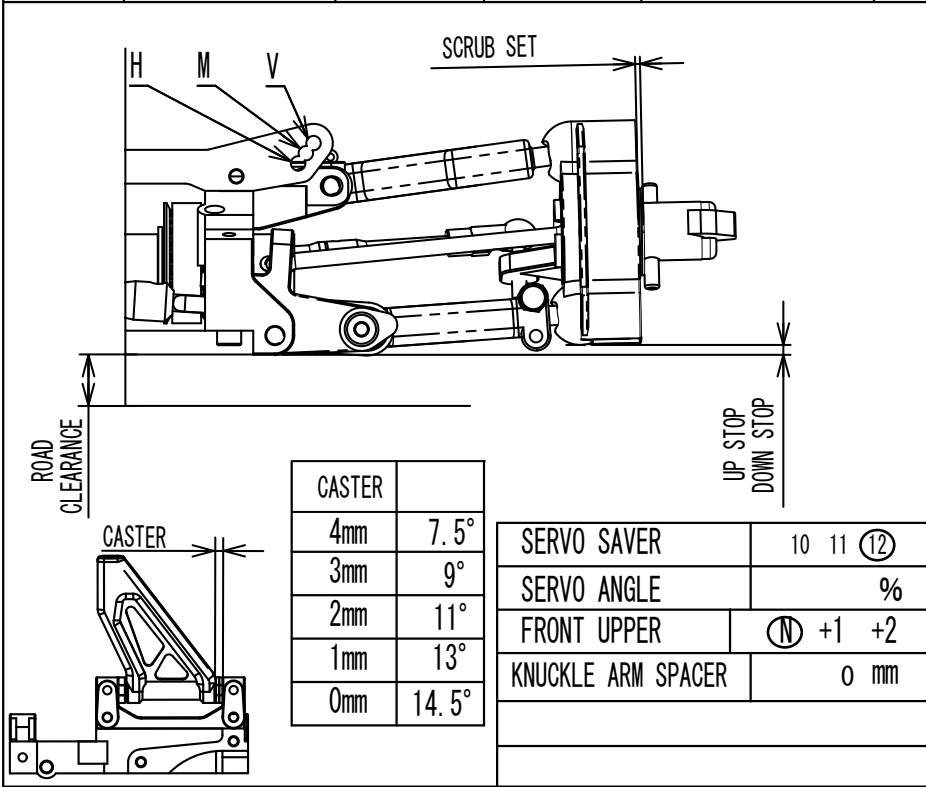

SHOCK OIL	400 450 (500) 550 600 700 800
DIAPHRAGM	
SHOCK PISTON	N Φ1.2-1Hole
SPRING	1.8 (1.9) 2.0 13mm φ1.9
SPRING ADJUSTER	mm
SHOCK POS	H (M) V
SCRUB SET	0.5 (1.0)
CASTER ANGLE	1 mm
CAMBER ANGLE	L (0) 0.5 1 1.5 2 2.5 3 R (0) 0.5 1 1.5 2 2.5 3
TOE ANGLE	-1°
FRONT WIDTH	253 mm
UP STOP	mm
DOWN STOP	0 mm
ANTIROLL BAR	⊖ ⊙ ⊗ ⊘ ⊙
TIRE HARDNESS	32 (35) 37 40
TIRE TYPE	(STANDARD) / MULTI
TIRE DIAMETER	φ 69 mm
ROAD CLEARANCE	7.5 mm

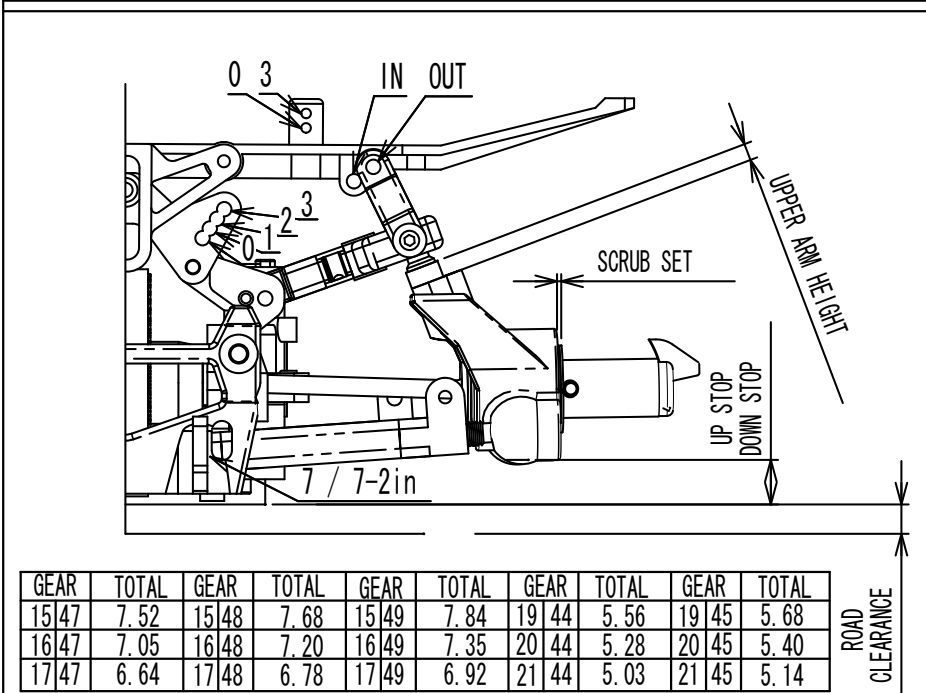

SHOCK OIL	400 450 (500) 550 600 700 800
DIAPHRAGM	
SHOCK PISTON	N Φ1.1×2 Hole
SPRING	1.8 1.9 (2.0) 13mm φ1.9
SPRING ADJUSTER	mm
SHOCK POS	0 (1) 2 3
SCRUB SET	0.5 (1.0) 1.5 2.0
UPPER ARM	3 mm (IN) OUT
CAMBER ANGLE	L 0.5 1 (1.5) 2 2.5 3 3.5 R 0.5 1 (1.5) 2 2.5 3 3.5
TOE ANGLE	+1.5°
REAR WIDTH	262 mm
UP STOP	mm
DOWN STOP	9 mm
ANTIROLL BAR	/ ∅
TIRE HARDNESS	32 (35) 37 40
TIRE TYPE	(STANDARD) / MULTI

GEAR	TOTAL	GEAR	TOTAL	GEAR	TOTAL	GEAR	TOTAL	GEAR	TOTAL
15/47	7.52	15/48	7.68	15/49	7.84	19/44	5.56	19/45	5.68
16/47	7.05	16/48	7.20	16/49	7.35	20/44	5.28	20/45	5.40
17/47	6.64	17/48	6.78	17/49	6.92	21/44	5.03	21/45	5.14

CLUCH TYPE	(3D) 4D	PINION GEAR	15 (16) 17 18/19 (20) 21 22
CLUCH SHOE	N RED (GREY)	SPUR GEAR	47 48 (49) (44) 45
HUGAL SHOE	N	DRIVE RATIO	(7mm Difference 26/18 (420 BELT))
CLUCH SPRING	4D	BODY MOUNT POS	IN / (OUT)
CLEARANCE	0.5 mm	BODY MOUNT HEIGHT	(0) / 3
ADJ. NUT	1.2 mm		

TIRE DIAMETER	φ 76 mm
ROAD CLEARANCE	8 mm
SUS HOLDER	(7) / 7-2in
BODY	KYOSHO
BODY POSITION	8 mm
REAR SPOILER	9 mm

MEMO