

NAME	Takaaki Shimo	TEMP	°C	ENGINE	Sirio	MUFFLER	Sirio 2013
DATE	2003/11/09	HUMIDITY	%	HEAD CLEARANCE	0.5 mm	FUEL TYPE	
TRACK	SPEED PARK KAGAWA	TRACTION	%	PLUG No.	7	RADIO	SANWA

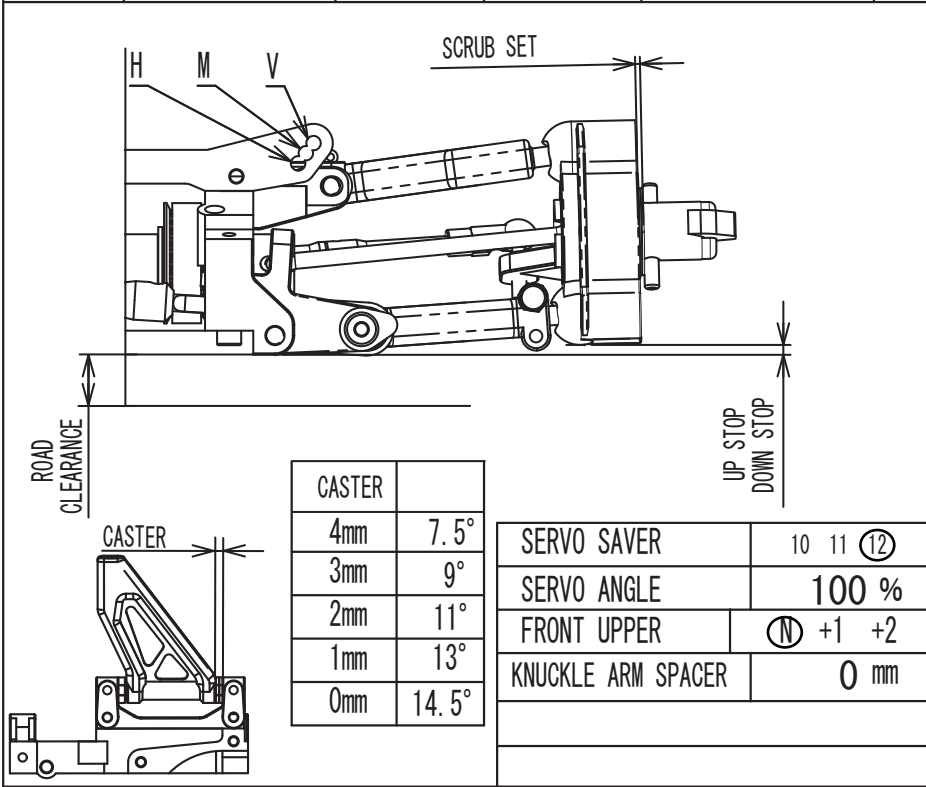

SHOCK OIL	400 450 (500) 550 600 700 800
DIAPHRAGM	
SHOCK PISTON	① Φ1.2-1Hole
SPRING	1.8 (1.9) 2.0   1.9-4.5 Silver
SPRING ADJUSTER	mm
SHOCK POS	Ⓜ M V
SCRUB SET	0.5 (1.0)
CASTER ANGLE	2 mm
CAMBER ANGLE	L ① 0.5 1 1.5 2 2.5 3 R ① 0.5 1 1.5 2 2.5 3
TOE ANGLE	-1°
FRONT WIDTH	252 mm
UP STOP	- mm
DOWN STOP	0 mm
ANTIROLL BAR	● ○ ○ ○ ○
TIRE HARDNESS	32 (35) 37 40
TIRE TYPE	(STANDARD) / MULTI
TIRE DIAMETER	φ 69 mm
ROAD CLEARANCE	7 mm

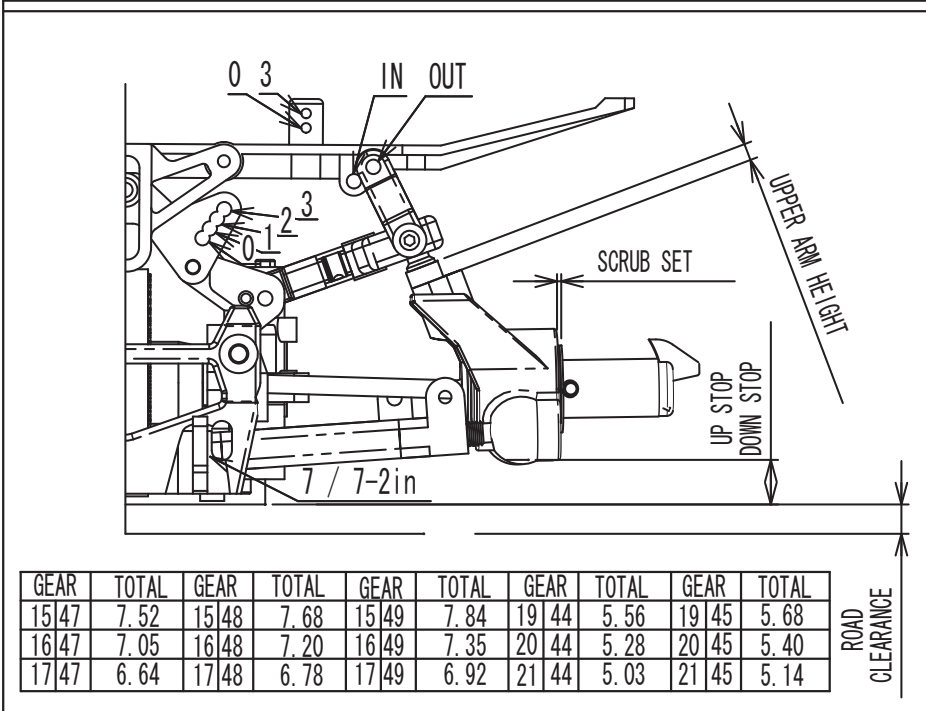

SHOCK OIL	400 450 (500) 550 600 700 800
DIAPHRAGM	
SHOCK PISTON	※ Φ1.2×1Hole
SPRING	1.8 1.9 (2.0)   2.0-5.5 Black
SPRING ADJUSTER	mm
SHOCK POS	0 ① 2 3
SCRUB SET	0.5 (1.0) 1.5 2.0
UPPER ARM	3 mm (IN) OUT
CAMBER ANGLE	L ① 0.5 1 1.5 2 2.5 3 3.5 R ① 0.5 1 1.5 2 2.5 3 3.5
TOE ANGLE	1.5°
REAR WIDTH	262 mm
UP STOP	- mm
DOWN STOP	9 mm
ANTIROLL BAR	φ3 / ○
TIRE HARDNESS	32 (35) 37 40
TIRE TYPE	(STANDARD) / MULTI

GEAR	TOTAL	GEAR	TOTAL	GEAR	TOTAL	GEAR	TOTAL	GEAR	TOTAL
15/47	7.52	15/48	7.68	15/49	7.84	19/44	5.56	19/45	5.68
16/47	7.05	16/48	7.20	16/49	7.35	20/44	5.28	20/45	5.40
17/47	6.64	17/48	6.78	17/49	6.92	21/44	5.03	21/45	5.14

CLUCH TYPE	(3D) 4D	PINION GEAR	(15) 16 17 18 (19) 20 21 22
CLUCH SHOE	N RED (GREY)	SPUR GEAR	47 (48) 49 / (44) 45
HUGAL SHOE	N	DRIVE RATIO	(7mm Difference) 26/18 (420 BELT)
CLUCH SPRING	4D	BODY MOUNT POS	IN / (OUT)
CLEARANCE	0.5 mm	BODY MOUNT HEIGHT	(0) / 3
ADJ. NUT	1.2 mm		

TIRE DIAMETER	φ 76 mm
ROAD CLEARANCE	7.5 mm
SUS HOLDER	7 / (7-2in)
BODY	KYOSHO LOLA (Light)
BODY POSITION	9 mm
REAR SPOILER	3 mm

MEMO