

EVOLVA M3

SETTING DATA SHEET Ver 2.00

NAME	TEMP	°C	ENGINE	MUFFLER
DATE	HUMIDITY	%	HEAD CLEARANCE	mm
TRACK	TRACTION	%	PLUG No.	RADIO

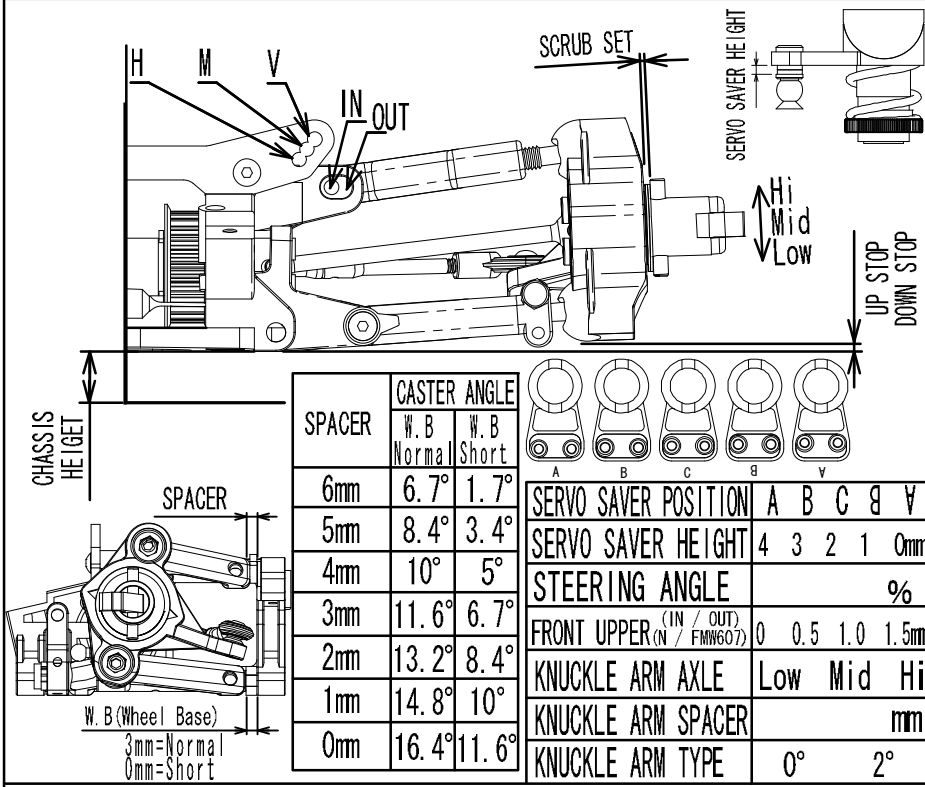

SPACER	CASTER ANGLE	
	W.B Normal	W.B Short
6mm	6.7°	1.7°
5mm	8.4°	3.4°
4mm	10°	5°
3mm	11.6°	6.7°
2mm	13.2°	8.4°
1mm	14.8°	10°
0mm	16.4°	11.6°

SERVO SAVER POSITION	A	B	C	B	V
SERVO SAVER HEIGHT	4	3	2	1	0mm
STEERING ANGLE	%				
FRONT UPPER (IN / OUT) (N / FMW607)	0	0.5	1.0	1.5	mm
KNUCKLE ARM AXLE	Low Mid Hi				
KNUCKLE ARM SPACER	mm				
KNUCKLE ARM TYPE	0°		2°		

SHOCK OIL	300 350 400 450 500 550 600
DIAPHRAGM	N
SHOCK PISTON	N
SPRING	1.8 1.9 2.0
SPRING ADJUSTER	mm
SHOCK POS	H M V
SCRUB SET	0.5 1.0 1.5 2.0
CASTER ANGLE / W.B	° / Normal Short
CAMBER ANGLE OG/1G	L 0 0.5 1 1.5 2 2.5 3 R 0 0.5 1 1.5 2 2.5 3
TOE ANGLE	°
FRONT WIDTH OG/1G	mm
UP STOP	mm
DOWN STOP	mm
ANTIROLL BAR VZ084 VZ084S	⊖ ⊗ ⊘ ⊙ ⊕
TIRE HARDNESS	32 35 37 40
TIRE TYPE	
TIRE DIAMETER	φ mm
CHASSIS HEIGHT	mm

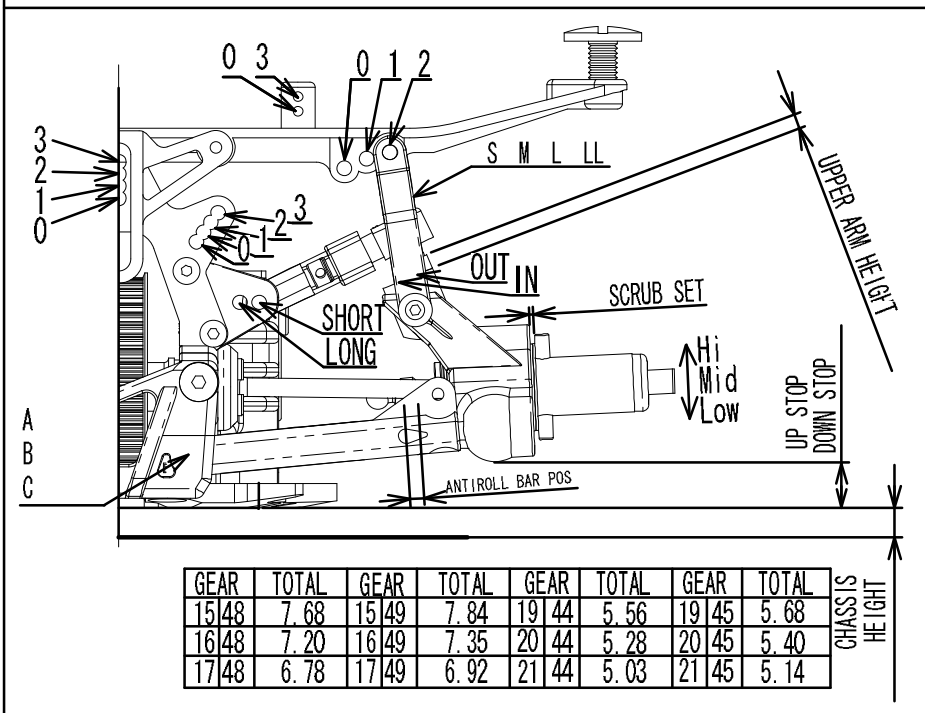

GEAR	TOTAL	GEAR	TOTAL	GEAR	TOTAL	GEAR	TOTAL
15/48	7.68	15/49	7.84	19/44	5.56	19/45	5.68
16/48	7.20	16/49	7.35	20/44	5.28	20/45	5.40
17/48	6.78	17/49	6.92	21/44	5.03	21/45	5.14

SHOCK OIL	400 450 500 550 600 700 800
DIAPHRAGM	N
SHOCK PISTON	N
SPRING	1.8 1.9 2.0
SPRING ADJUSTER	mm
SHOCK POS	0 1 2 3
SCRUB SET	0.5 1.0 1.5 2.0
UPPER ARM LONG/SHORT IN/OUT	mm
CAMBER ANGLE OG/1G	L 0.5 1 1.5 2 2.5 3 3.5 R 0.5 1 1.5 2 2.5 3 3.5
TOE ANGLE	°
REAR WIDTH OG/1G	mm
UP STOP	mm
DOWN STOP	mm
ANTIROLL BAR /POS	φ 3 / ○ mm
TIRE HARDNESS	32 35 37 40
TIRE TYPE	
TIRE DIAMETER	φ mm
CHASSIS HEIGHT	mm

CLUTCH TYPE	2D 3D 4D	PINION GEAR	15 16 17 / 19 20 21	TIRE DIAMETER	φ mm
CLUTCH SHOE	BLACK RED GREY	SPUR GEAR	48 49 / 44 45	CHASSIS HEIGHT	mm
CENTRIFUGAL SHOE	N	DRIVE RATIO	7mm Difference 26/18(420 BELT)	SUS HOLDER	A / B / C
CLUTCH SPRING		CENTER POST POSITION	0 / 1 / 2 / 3	REAR HUB AXLE	Low / Mid / Hi
CLEARANCE	mm	BODY MOUNT ANGLE	0 / 1 / 2	REAR WHEEL BASE	SHORT / LONG
ADJ. NUT	mm	BODY MOUNT HEIGHT	S/M/L/LL 0/3	BODY	
F-ONEWAY POS	UP / DOWN	FRONT CARBON	USE / NOT USE	BODY POSITION	mm
BATTERY PLATE	N / CARBON / STAINLESS	SIDE CARBON	USE / NOT USE	REAR SPOILER	mm

MEMO