

# EVOLVA M3

## SETTING DATA SHEET Ver 1.00

NAME	L. Collari	TEMP	4 °C	ENGINE	Nova Rossi	MUFFLER	3007
DATE	11.02.08	HUMIDITY	%	HEAD CLEARANCE	0.5 mm	FUEL TYPE	
TRACK	Fiorano	TRACTION	85 %	PLUG No.	7TF	RADIO	SANWA

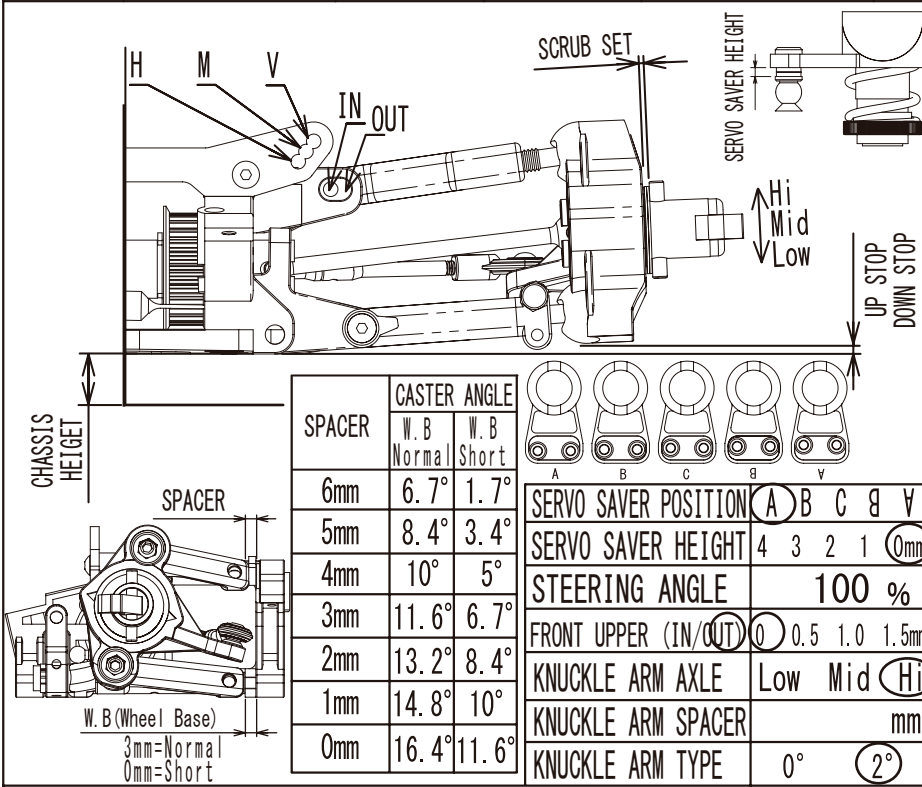

SHOCK OIL	300 350 400 450 (500) 550 600
DIAPHRAGM	(N)
SHOCK PISTON	(N) φ1.2-1
SPRING	1.8 (1.9) 2.0 Kyosho White
SPRING ADJUSTER	8 mm
SHOCK POS	(H) M V
SCRUB SET	(0.5) 1.0 1.5 2.0
CASTER ANGLE / W.B	8.4° (Normal) Short
CAMBER ANGLE	L 0 0.5 1 1.5 2 2.5 3 R 0 0.5 1 1.5 2 2.5 3
TOE ANGLE	-1.5 °
FRONT WIDTH OG/1G	252 mm
UP STOP	mm
DOWN STOP	0 mm
ANTIROLL BAR	VZ084 VZ084S (●) (○) (○) (○) (○)
TIRE HARDNESS	(32) 35 37 40
TIRE TYPE	PMT
TIRE DIAMETER	φ 69 mm
CHASSIS HEIGHT	7.5 mm

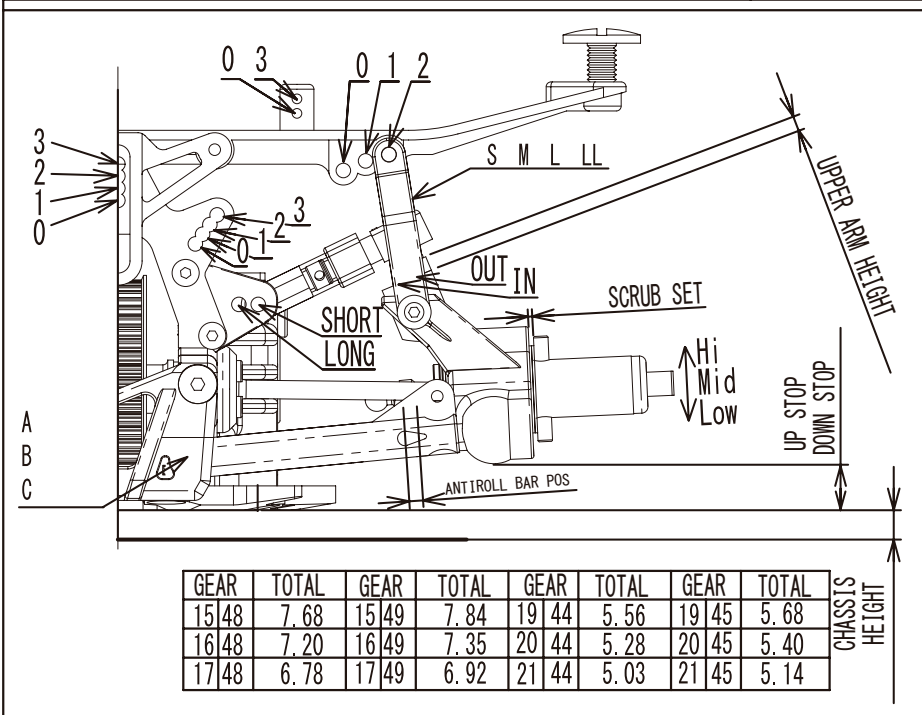

SHOCK OIL	400 450 (500) 550 600 700 800
DIAPHRAGM	(N)
SHOCK PISTON	(N) φ1.1-2
SPRING	1.8 (1.9) 2.0 Kyosho White
SPRING ADJUSTER	7.5 mm
SHOCK POS	0 (1) 2 3
SCRUB SET	0.5 (1.0) 1.5 2.0
UPPER ARM	LONG (SHORT) (IN) (OUT) mm
CAMBER ANGLE	L 0.5 1 1.5 2 2.5 3 3.5 R 0.5 1 1.5 2 2.5 3 3.5
TOE ANGLE	3 °
REAR WIDTH OG/1G	264 mm
UP STOP	mm
DOWN STOP	9 mm
ANTIROLL BAR / POS	(φ3) / (○) mm
TIRE HARDNESS	32 (35) 37 40
TIRE TYPE	PMT
TIRE DIAMETER	φ 76 mm
CHASSIS HEIGHT	8.5 mm

CLUTCH TYPE	2D (3D) 4D	PINION GEAR	15 (16) 17 / 19 (20) 21	TIRE DIAMETER	φ 76 mm
CLUTCH SHOE	BLACK RED GREY	SPUR GEAR	48 (49) / 44 (45)	CHASSIS HEIGHT	8.5 mm
CENTRIFUGAL SHOE	N	DRIVE RATIO	7mm Difference 26/18(420 BELT)	SUS HOLDER	A / B / (C)
CLUTCH SPRING		CENTER POST POSITION	0 / 1 / 2 (3)	REAR HUB AXLE	Low / (Mid) / Hi
CLEARANCE	mm	BODY MOUNT ANGLE	0 / (1) / 2	REAR WHEEL BASE	SHORT / (LONG)
ADJ. NUT	mm	BODY MOUNT HEIGHT	S/M(L)LL(0)3	BODY	L. Collari PEUGEOT 908
F-ONEWAY POS	UP / (DOWN)	FRONT CARBON	USE / (NOT USE)	BODY POSITION	11 mm
BATTERY PLATE	(N) / CARBON	SIDE CARBON	USE / (NOT USE)	REAR SPOILER	4 mm

MEMO