

V-ONE RR Evo.

SETTING DATA SHEET Ver1.00

NAME		TEMP	°C	ENGINE		MUFFLER	39065	MANIFOLD	39065
DATA		HUMIDITY	%	HEAD CLEARANCE	mm	FUEL TYPE			
TRACK		TRACTION	%	PLUG No.		RADIO			

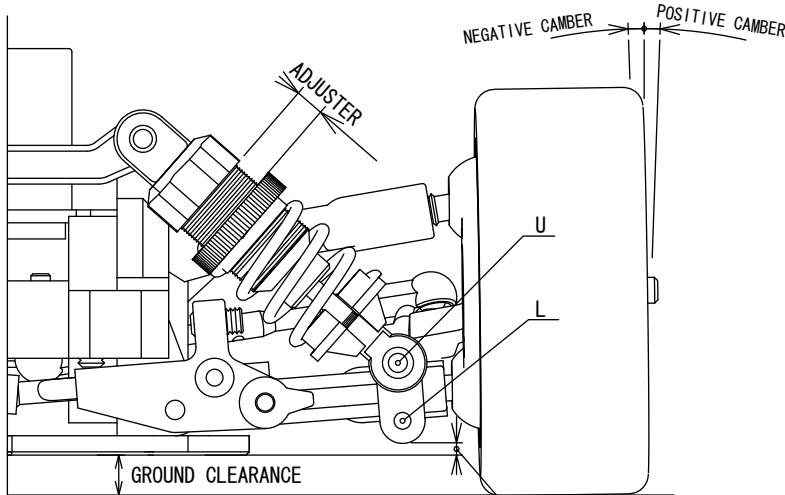

SHOCK OIL	300 350 400 450 (500) 550 600 700
SHOCK PISTON	N
SPRING	SILVER BLACK GOLD
SPRING ADJUSTER	mm
SHOCK POS	(U) L
CASTER ANGLE	3 mm
CAMBER ANGLE	OG (1G) 0 0.5 (1.0) 1.5 2.0
TOE ANGLE	mm
FRONT WIDTH	mm
BUMP STROKE	mm
REBOUND STOP	mm
STABILIZER BAR	<input checked="" type="radio"/> <input type="radio"/> <input type="radio"/> <input type="radio"/> <input type="radio"/>
TIRE TYPE	GRP35°
TIRE SIZE	φ 60 mm
GRAND CLEARANCE	6 mm
DIFF. /ONEWAY	

	CASTER ANGLE	
	4mm	6°
	3mm	8°
	2mm	10°
	1mm	12°
0mm	14°	

SERVO SAVER	(10) 11 12
ST D/R	90 %
BRAKE RATE	%
UPPER POS	N

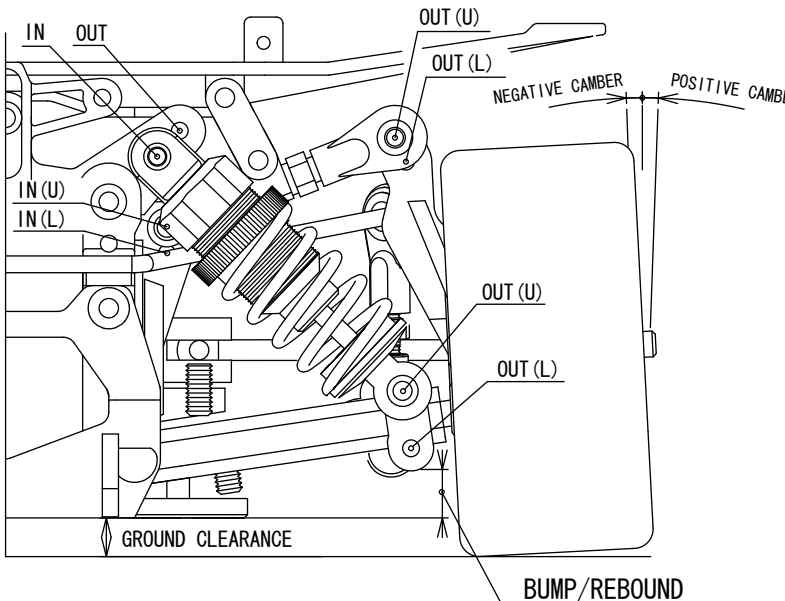

SHOCK OIL	300 350 400 450 (500) 550 600 700
SHOCK PISTON	N
SPRING	SILVER BLACK GOLD
SPRING ADJUSTER	6.5 mm
SHOCK POS	U (IN) OUT) - L (U (L))
UPPER ARM POS	IN (U (L)) - OUT (U (L))
CAMBER ANGLE	OG / 1G 0 0.5 1.0 (1.5) 2.0 2.5 3.0
TOE ANGLE	One Side 2.5°
REAR WIDTH	200 mm
BUMP STROKE	- mm
REBOUND STOP	4 mm
STABILIZER BAR	SILVER BLACK GOLD
DIFF OIL	# 5,000
TIRE TYPE	GRP35°
TIRE SIZE	φ 64 mm
GRAND CLEARANCE	6.5 mm
SIDE PULLEY	(25) 26 27
BODY	

GEAR	TOTAL	GEAR	TOTAL	GEAR	TOTAL	GEAR	TOTAL	GEAR	TOTAL					
20	59	7.45	21	59	7.10	22	59	6.78	25	55	5.56	26	56	5.44
20	60	7.58	21	60	7.22	22	60	6.89	25	56	5.66	27	55	5.15
20	61	7.71	21	61	7.34	22	61	7.00	26	55	5.34	27	56	5.24

CLUCH TYPE	(3D) / 4D	SPRING	Hard (1.8-1.0) Standard	BODY POSITION	N
CLUCH WEIGHT	N	GEAR	20 (21) 22 / 25 (26) 27	REAR SPOILER HEIGHT	N
CLUCH SHOE	Gray	GEAR	59 60 (61) / 55 (56)	REAR SPOILER ANGLE	N
CLEARANCE	0.5 mm				
ADJUST NUT	0.5 mm				