

NAME	KIKUCHI	TEMP	28 °C	ENGINE	GXR15	MUFFLER	No. 39064
DATE	05.08.28	HUMIDITY	50 %	HEAD CLEARANCE	- mm	FUEL TYPE	BPピークパワー
TRACK	日本海スピードウェイ	TRACTION	80 %	PLUG No.	GS	RADIO	SANWA M11

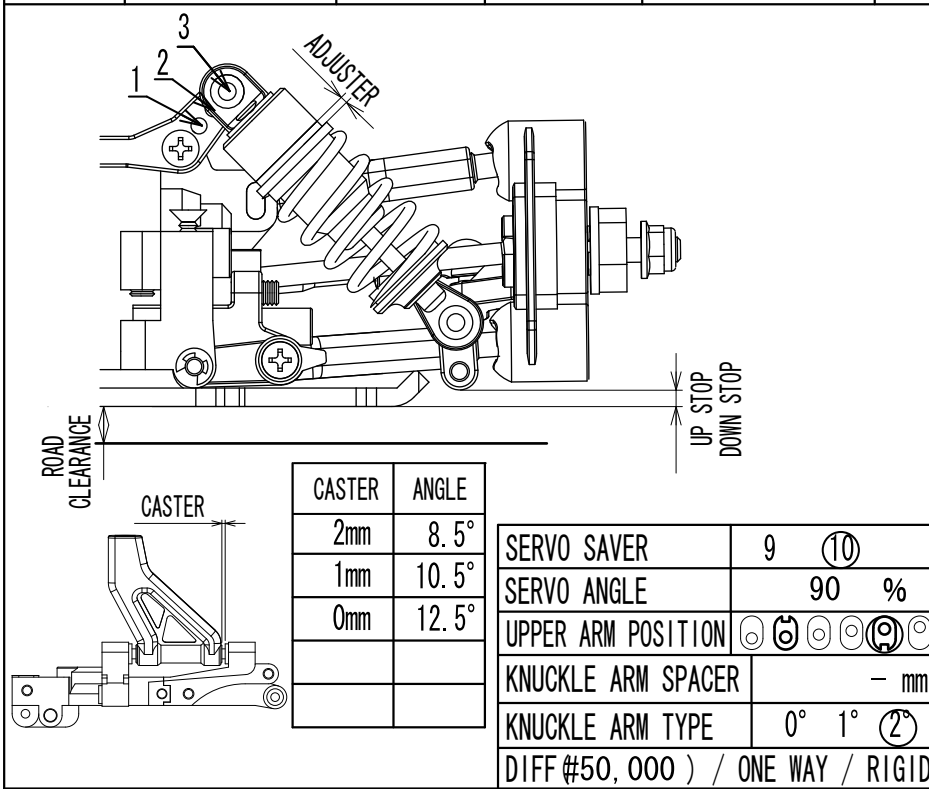

SHOCK OIL	300 350 (400) 450 500 550 600
SHOCK TYPE	✚ / (VZ075)
DIAPHRAGM	✚ W6006
SHOCK PISTON	✚ φ1.0 - 2
SPRING	✚ (No. 92491) グリーン
SPRING ADJUSTER	車高に併せる mm
SHOCK POSITION	1 (2) 3
CASTER ANGLE	1 mm
CAMBER ANGLE	L (0.5) 0 0.5 1 1.5 2 2.5 3 R (0.5) 0 0.5 1 1.5 2 2.5 3
TOE ANGLE	-0.5°
FRONT WIDTH	199 mm
UP STOP	- mm
DOWN STOP	-1 mm
SERVO SAVER	9 (10)
SERVO ANGLE	90 %
UPPER ARM POSITION	⊙ ⊕ ⊗ ⊘ ⊙ ⊙
KNUCKLE ARM SPACER	- mm
KNUCKLE ARM TYPE	0° 1° (2°)
DIFF (#50,000) / ONE WAY / RIGID	
ANTIROLL BAR	有 VZ084S ⊖ ⊗ ⊘ ⊙ ⊙ 無 VZ084
TIRE TYPE & HARDNESS	Vスリック35MN
INNER FOAM	92906S(モールド)
WHEEL TYPE	92012
CHASSIS HEIGHT	6 mm

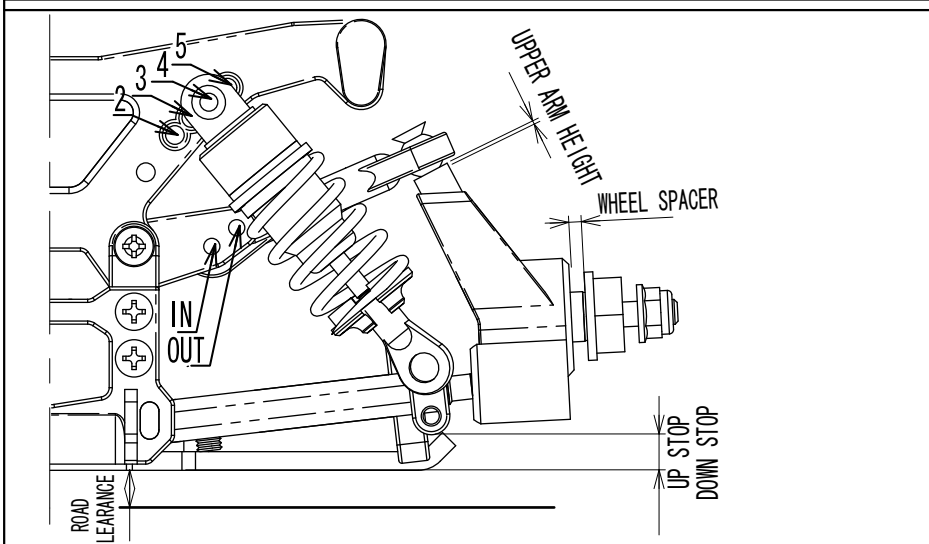

SHOCK OIL	✚ 300 350 (400) 450 500 550 600
SHOCK TYPE	✚ / (VZ075)
DIAPHRAGM	✚ W6006
SHOCK PISTON	✚ φ1.0 - 2
SPRING	✚ (No. 92491) グリーン
SPRING ADJUSTER	車高に併せる mm
SHOCK POS	1 2 (3) 4
WHEEL SPACER	(0mm) / 2mm
UPPER ARM HEIGHT	0 mm (IN/OUT)
CAMBER ANGLE	L (0) 0.5 1 1.5 2 2.5 3 3.5 4 R (0) 0.5 1 1.5 2 2.5 3 3.5 4
TOE ANGLE	2.5°
REAR WIDTH	200 mm
DOWN STOP	3 mm
ANTIROLL BAR	無 (3)/1.4
TIRE TYPE & HARDNESS	Vスリック35MN
INNER FOAM	92906S(モールド)
WHEEL TYPE	92012
CHASSIS HEIGHT	6.7 mm

GEAR	TOTAL	GEAR	TOTAL	GEAR	TOTAL	GEAR	TOTAL	GEAR	TOTAL					
15	61	8.13	15	60	8.00	15	59	7.87	20	56	5.60	20	55	5.50
16	61	7.63	16	60	7.50	16	59	7.38	21	56	5.33	21	55	5.24
17	61	7.18	17	60	7.06	17	59	6.94	22	56	5.09	22	55	5.00
									23	56	4.87	23	55	4.78

FLYWHEEL	✚ VS057	PINION GEAR	(15) 16 17 / 20 (21) 22 23	SHOCK OIL	✚ 300 350 (400) 450 500 550 600
CLUCH SHOE	(N) UM210	SPUR GEAR	59 60 (61) / 55 (56)	SHOCK TYPE	✚ / (VZ075)
CLUTCH SPRING	N	BRAKE	70 %	DIAPHRAGM	✚ W6006
		REAR DIFF	#3,000(4ベベル)	SHOCK PISTON	✚ φ1.0 - 2
				SPRING	✚ (No. 92491) グリーン
				SPRING ADJUSTER	車高に併せる mm
				SHOCK POS	1 2 (3) 4
				WHEEL SPACER	(0mm) / 2mm
				UPPER ARM HEIGHT	0 mm (IN/OUT)
				CAMBER ANGLE	L (0) 0.5 1 1.5 2 2.5 3 3.5 4 R (0) 0.5 1 1.5 2 2.5 3 3.5 4
				TOE ANGLE	2.5°
				REAR WIDTH	200 mm
				DOWN STOP	3 mm
				ANTIROLL BAR	無 (3)/1.4
				TIRE TYPE & HARDNESS	Vスリック35MN
				INNER FOAM	92906S(モールド)
				WHEEL TYPE	92012
				CHASSIS HEIGHT	6.7 mm
				LOWER ARM POSITION	⊙ ⊕ ⊗ ⊘ ⊙ ⊙
				BODY	スープラ2005
				WING HEIGHT	N mm

MEMO